

A grey Bullet Express Trio blender is shown in the background. The blender has a clear plastic jar with a black lid and a black base. The base has a control panel with buttons for 'Pulse', 'High', 'Low', and 'Off'. The brand name 'BULLET EXPRESS TRIO' is printed on the front of the base.

BULLET *Express* TRIO™

The Amazing 8 Minute Meal Machine™

USER MANUAL

IMPORTANT SAFEGUARDS AND CAUTIONARY INFORMATION

FOR YOUR SAFETY, CAREFULLY READ ALL INSTRUCTIONS BEFORE OPERATING BULLET EXPRESS TRIO

When using electrical appliances, basic safety precautions should always be followed including the following:

- This appliance is not intended for use by persons (including children) with reduced physical, sensory or mental capabilities, or lack of experience and knowledge, unless they have been given supervision or instruction concerning use of the appliance by a person responsible for their safety.
- Children should be supervised to ensure that they do not play with the appliance.
- If the supply cord is damaged, it must be replaced by the manufacturer, its service agent or similarly qualified persons in order to avoid a hazard.
- Care is needed when handling cutting blades, especially when removing from the bowl and during cleaning.
- Caution! To avoid risk of electrical shock, never immerse the cord, plug or **Motor Base** in water or other liquids.
- Do not use attachments that are not recommended or sold by the manufacturer as doing so may cause damage, fire, electric shock or injury and will void the warranty.
- Do not pull, twist or mistreat the power cord.
- Do not allow the power cord to hang over the side of the counter or table.
- Do not allow the power cord to touch hot surfaces, including stove.
- Unplug the **Bullet Express Trio** when it is not in use, before putting on or taking off parts and before cleaning or assembling. When not in use, do not store blades or discs on the motor shaft.
- Make sure that the **Safety Clamps** securely lock the cover in place and that the **Feed Tube Pusher** is properly inserted, before operating the **Bullet Express Trio**.
- Do not attempt to defeat or override the cover interlock **Safety Clamp** mechanism.
- Avoid contact with cutting blades, discs, and moving parts of the **Bullet Express Trio**. Never push food down into the feed tubes by hand. Always use the proper **Feed Tube Pusher** or injury can occur.
- Keep hands and utensils out of feed tubes and away from the cutting blades while **Bullet Express Trio** is running to reduce risk of severe injury to person or damage to the **Bullet Express Trio**. To use a scraper, turn the **Bullet Express Trio** off and unlock the safety clamps.
- To avoid injury from moving parts or food debris when operating **Bullet Express Trio**, keep face and fingers out of and away from the **Meal Maker** discharge outlet.
- Make sure the motor has completely stopped before removing covers.
- Always put ingredients in the **Meal Mixer Bowl** first, before operation. **Never turn on when bowl is empty.**
- Always make sure **Juicer Cover** is clamped securely in place and **Juicer Spout** is securely inserted on to the **Juicer Bowl** before operating the juicer. Do not unfasten clamps while the juicer is in operation. Turn off juicer prior to removing **Juice Pulp Container** for emptying.
- To avoid clogs in the **Juicer Feed Tube**, foods should be cut to sizes no larger than 2 inches in diameter. If food does become lodged in the feed tube, use **Feed Tube Pusher** only to push the lodged particles down. If this does not unclog the tube, turn off the **Bullet Express Trio** and disassemble the juicer to remove the remaining lodged food.
- Do not use **Bullet Express Trio** if the rotating **Juicer Filter** is damaged.
- Always use your **Bullet Express Trio** on a clean, flat, hard, dry surface.
- Do not use the **Bullet Express Trio** outdoors in the rain or in wet conditions.
- Never leave the **Bullet Express Trio** unattended while it is in use.
- Close supervision is necessary when any appliance is used by or near children.
- Blades and discs are sharp. Handle carefully.
- Flashing red light indicates **Bullet Express Trio** is ready to operate. Avoid any contact with blades or moveable parts.
- Do not place any of the **Bullet Express Trio** containers or bowls in a microwave.
- **Never keep the blades running for more than three (3) minutes at a time, as it can cause permanent damage to the motor.** If the motor stops working, unplug the **Motor Base** and let it cool for up to 1 hour before attempting to use it again. Your **Bullet Express Trio** has an internal thermal breaker that shuts off the unit when it overheats. Letting the thermal breaker cool down will allow the **Motor Base** to reset.

SAVE THESE INSTRUCTIONS
FOR HOUSEHOLD USE ONLY

FEATURES OF THE BULLET EXPRESS TRIO

- Multi-purpose food processing functions of juicing, mixing, chopping, blending, slicing, shredding and mincing.
- Two-way safety system: Your **Bullet Express Trio** will not operate unless the **Safety Clamps** are engaged and the work bowls and covers are properly locked on the **Motor Base**.
- A powerful 700W motor that will chop, blend, shred, slice and mix in a matter of seconds.
- A detachable system for multi-functions and easy cleaning.
- The extra-wide feed tubes are perfect for juicing and slicing whole fruits and vegetables.
- State-of-the-Art operating and safety design.



TABLE OF CONTENTS

What You Get	1 - 2
Motor Base	1
Meal Maker Express Assembly Components	1
Meal Mixer Express Assembly Components	2
Juicer Express Assembly Components	2
Assembling the Bullet Express Trio	3 - 6
Meal Maker Express Assembly Instructions	3
How to Use the Slicer and Shredder Disc	4
Meal Mixer Express Assembly Instructions	5
Juicer Express Assembly Instructions	6
Operating the Bullet Express Trio Control Panel	7
Using the Pulse Technique	8
Bullet Express Trio Capacities	8
How to Maintain Your Bullet Express Trio	9
Bullet Express Trio Electrical Specifications	10



WHAT YOU GET

- 1** Your **Bullet Express Trio** has three main component assemblies that perform the multiple functions of the machine. The assemblies are the **Meal Maker**, **Meal Mixer** and **Juicer**. The **Motor Base** (see below) is the common mechanism that powers the other components. The **Safety Clamps** on the **Motor Base** hold the other components safely in place during operation. Note: The unit will not operate unless the **Safety Clamps** are properly engaged and securely locked on to a work bowl cover.

MOTOR BASE:



Motor Base
(Common to All Assemblies)

- 2** The **Meal Maker Express Assembly** is used for slicing and shredding a variety of vegetables, fruits, cheeses, etc. (see components below):

MEAL MAKER EXPRESS ASSEMBLY Components:

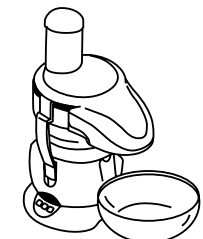
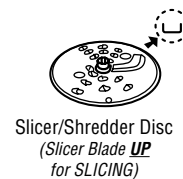
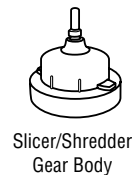

WHAT YOU GET

3 The **Meal Mixer Express Assembly** is used for a variety of functions including ice crushing, mixing, blending, chopping, mincing, etc. (see components below):

MEAL MIXER EXPRESS ASSEMBLY Components:

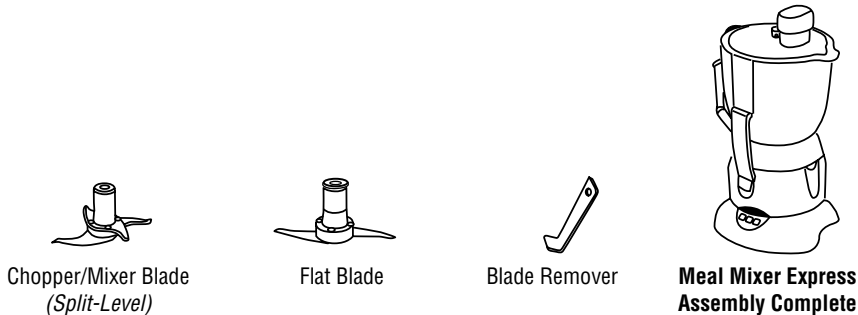

4 The **Juicer Express Assembly** can be used for juicing all types of fruits and vegetables (see components below):

JUICER EXPRESS ASSEMBLY Components:

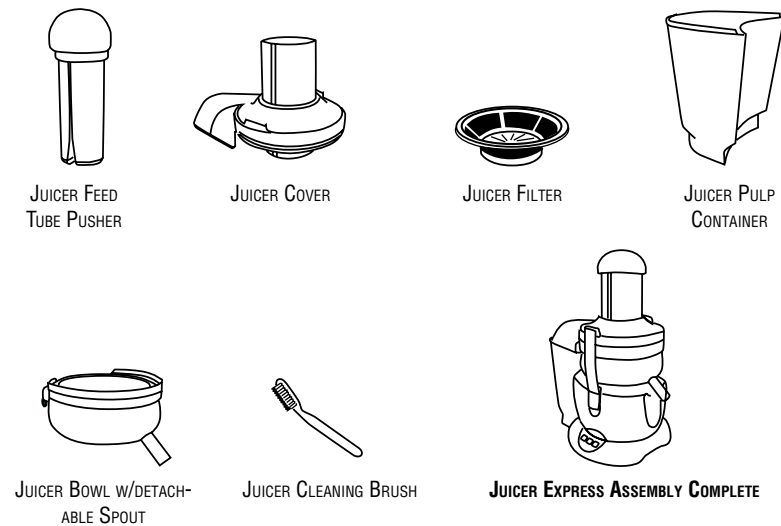

ASSEMBLING THE BULLET EXPRESS TRIO

MEAL MAKER EXPRESS ASSEMBLY INSTRUCTIONS

A. Put the **Slicer/Shredder Gear Body** on the **Motor Body** and then place the **Slicer/Shredder Bowl** on the **Slicer/Shredder Gear Body** shaft.

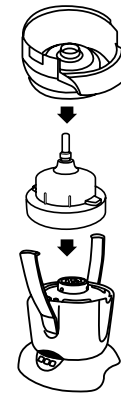

B. Put the **Outlet Disc** on the **Slicer/Shredder** shaft and then place the **Slicer/Shredder** disc on the shaft in the desired direction (**Slicer Blade UP** for Slicing, **DOWN** for Shredding). *Use caution when handling sharp discs.*

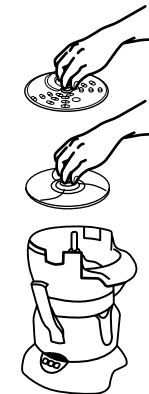

C. Place the **Slicer/Shredder Cover** over the **Bowl** and attach the **Safety Clamps**.

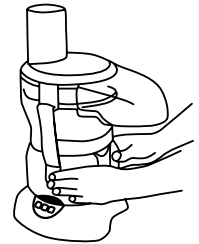

D. Place your own bowl or container under the **Slicer/Shredder Cover** outlet.

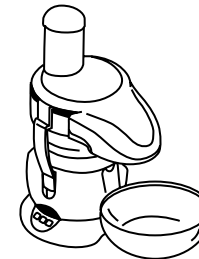

E. Push the "Low" **ON** button first and then put in your vegetables/fruits using the **Small Food Pusher**.

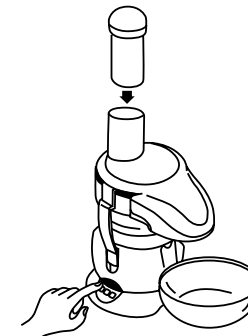

NOTE: To disassemble, just reverse the procedure above.

HOW TO USE THE SLICER/SHREDDER DISC

Use the Slicer/Shredder Disc in the manner required for the desired results.

Slicing

For SLICING, the Slicer Blade should be UP.

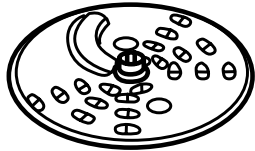

Blade Direction (UP)

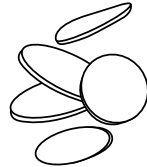

Slicing Results



Button

Shredding

For SHREDDING, the Slicer Blade should be DOWN (see below).

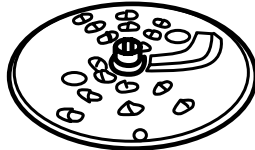

Blade Direction (DOWN)

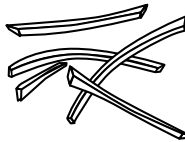

Shredding Results



Button

MEAL MIXER EXPRESS ASSEMBLY INSTRUCTIONS

- A. Insert desired blade onto the spindle axle of the **Meal Mixer Bowl**. Use caution while handling sharp blades. **NOTE: Always put ingredients in first before using Mixer Attachments. Never turn on when bowl is empty.**

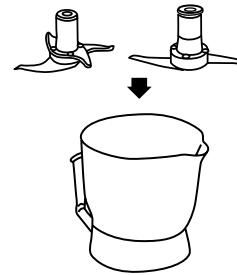

- B. Put ingredients into the **Meal Mixer Bowl** and place the **Cover** and **Feeder Hole Plug** on the **Bowl**.

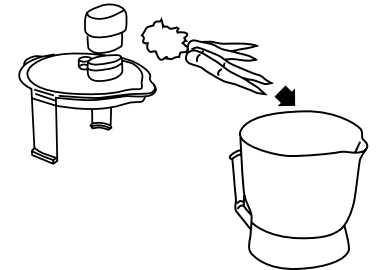

- C. Put the **Meal Mixer Bowl** on the **Motor Base** and place the **Motor Base Safety Clamps** over the side clamps of the **Bowl Cover**. Lock the **Safety Clamps** with both hands until you hear a click.

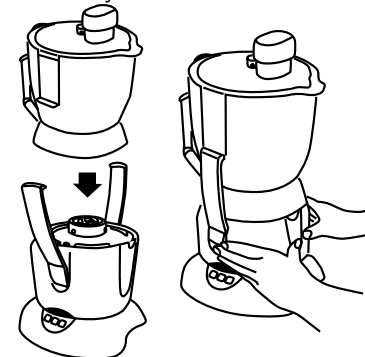

- D. Push the **HI, LOW** or **PULSE** button (as per your **Recipe Manual**) to operate.

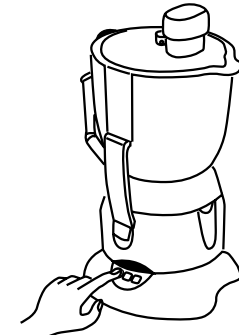

- E. **HOW TO USE THE BLADE REMOVER:**

CAUTION: When a blade cannot be removed by grasping the shaft with your fingers, please use the Blade Remover as shown. BLADES ARE VERY SHARP USE CAUTION WHEN REMOVING THE BLADE. Insert the shorter bent lifting edge under the center part of the blade and press the handle back away from the blade to release the blade from the shaft.



Blade Remover

NOTE: To disassemble, just reverse the procedure above.

JUICER EXPRESS ASSEMBLY INSTRUCTIONS

A. Put Juicer Bowl on Motor Body.
Insert **Juicing Filter** firmly into **Bowl**.
Be sure the **Juicer Spout** is firmly
inserted into the bowl.

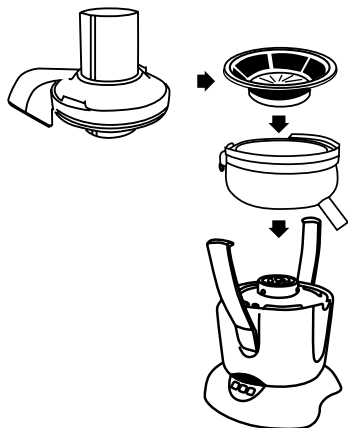

B. Put Juicer Cover on Juicer Bowl
and lock **Safety Clamps** firmly with
both hands until you hear a click.

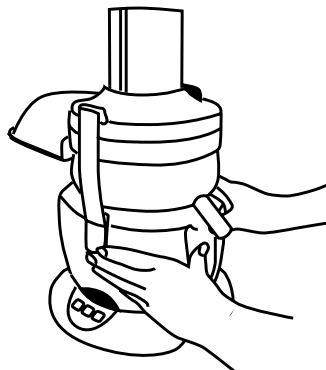

C. Put Pulp Container securely under
Juicer Cover outlet.

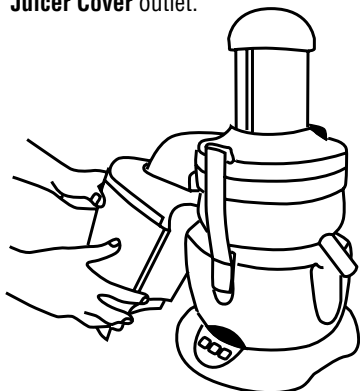

D. Push the "LOW" ON
button first and then
put in your vegeta-
bles/fruits using the
Feed Tube Pusher.

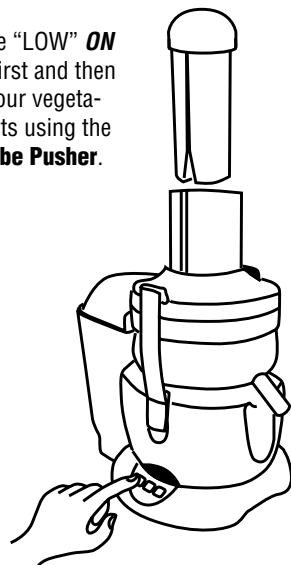

NOTE: To disassemble, just reverse the procedure above.

OPERATING THE BULLET EXPRESS TRIO CONTROL PANEL

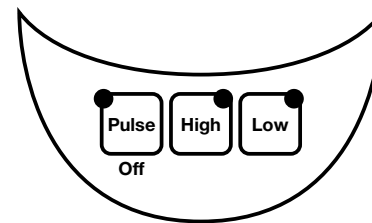

❶ JUICING FUNCTION

- Use **Juicer Express Assembly**
- Operate on **LOW**
- Make natural vegetable and fruit juices
- Make purées for soups, sauces, tofu, etc

❷ CRUSHING FUNCTION

- Use **Meal Mixer Express Assembly**
- Use **Flat Blade**
- Operate on **HIGH**
- Finely crush dried beans, peas, etc.

❸ SLICING FUNCTION

- Use **Meal Maker Express Assembly**
- Use **Slicer Disc**
- Operate on **LOW**
- Slice all types of vegetables

❹ DOUGH MIXING FUNCTION

- Use **Meal Mixer Express Assembly**
- Use **Flat Blade**
- Operate on **HIGH** or **LOW**
(As pertains to recipe book)
- **Mixing Dough**

❺ SHREDDING FUNCTION

- Use **Meal Maker Express Assembly**
- Use **Shredder Disc**
- Operate on **LOW**
- Shred vegetables, cheese, etc.

❻ SHAVED ICE FUNCTION

- Use **Meal Maker Express Assembly**
- Use **Slicer Disc**
- Operate on **HIGH**
- **Shave Ice**

❼ CHOPPING FUNCTION

- Use **Meal Mixer Express Assembly**
- Use **Chopper/Mixer (Split Level) Blade**
- Operate with **PULSE** button
- Chop **Garlic, Onions, Peppers, Meat, Fish,**
etc.

❽ MIXING FUNCTION

- Use **Meal Mixer Express Assembly**
- Use **Chopper/Mixer (Split Level) Blade**
- Operate on **HIGH** or **LOW**
- Mix smoothies, cake batters, etc.

USING THE PULSE TECHNIQUE

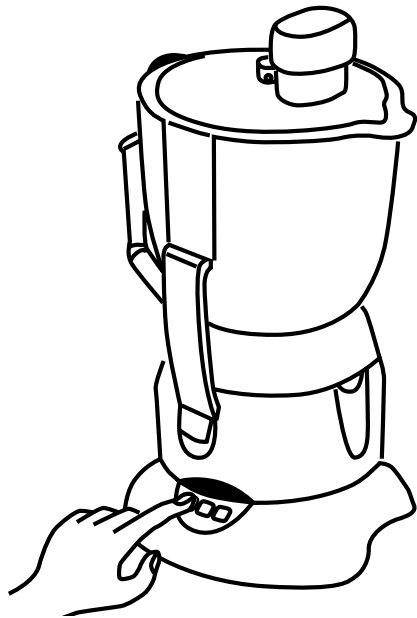

PULSE TECHNIQUE

The **Bullet Express Trio** motor is so powerful, if you aren't careful you can quickly over-process food and turn it into mush. This is where the Pulse Technique is key.

To Pulse, simply press the Pulse button and immediately release. Let the motor completely stop and Pulse again until desired results have been achieved.

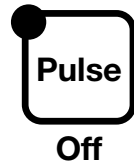

BULLET EXPRESS TRIO CAPACITIES

Recommended capacities for various foods and functions

Task	Food/Ingredient	Blade	Bowl Type	Maximum Time	Directions
Mincing	Raw Beef	Chopper/Mixer	Mixing Bowl	15 Seconds	Cut maximum of 400g into 2.5cm cubes.
Chopping	Onions	Chopper/Mixer	Mixing Bowl	15 Seconds	Chop maximum of 500g to ensure evenly sized pieces.
Grinding	Coffee Beans	Flat Blade	Mixing Bowl	15 Seconds	Chop maximum of 300g to ensure evenly sized pieces.
Grinding	Dry Soybeans	Flat Blade	Mixing Bowl	15 Seconds	Chop maximum of 300g to ensure evenly sized pieces.
Chopping	Apples	Chopper/Mixer	Mixing Bowl	15 Seconds	Cut maximum 500g into 2.5cm cubes before chopping.
Crushing	Ice	Flat Blade	Mixing Bowl	15 Seconds	Crush up to 500g of ice cubes using the pulse button.
Dough Mixing	Flour & Water	Flat Blade	Mixing Bowl	15 Seconds	Mix up to 400mls of water into a maximum of 340g of flour to make dough.
Slicing/Shredding	Carrots	Slicer/Shredder	Slicer/Shredder Bowl	3 Minutes	Slice/Shred up to a maximum of 2.5kgs.

HOW TO MAINTAIN YOUR BULLET EXPRESS TRIO

A. Wash with warm water and neutral detergent and wipe with a dish towel. Do not use an abrasive scrubber. Clean the **Juicer Filter** and **Removable Spout** with the **Cleaning Brush** supplied. **CAUTION:** Be careful when you clean blades and discs which are sharp and can cut.



B. Remove the detachable **Juicer Spout** for easy cleaning.

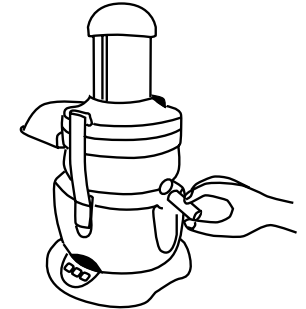

C. Clean **Motor Base** and **Meal Maker Gear Body** with a damp cloth and mild detergent.



D. When washing your **Bullet Express Trio** do not use any chemical cleaners as they may discolor or ruin the appearance of your machine.



CAUTION: Do not immerse the **Motor Body** or **Slicer/Shredder Gear Body** in water. Water in the motor can cause malfunctions or electrical shock. Periodically check plug and cord for damage.

BULLET EXPRESS TRIO ELECTRICAL SPECIFICATIONS

NOTES

MODEL:	Bullet Express Trio
MODEL NUMBER :	BE-110
VOLTAGE/HERZ:	AC220V~240V 50Hz/60Hz
RATING:	700 WATTS Max
MEAL MIXER BOWL CAPACITY:	1.18 Litres
MAXIMUM CONTINUOUS USE:	3 Minutes

NOTES

NOTES

NOTES